

M11 INSTALLATION INSTRUCTIONS

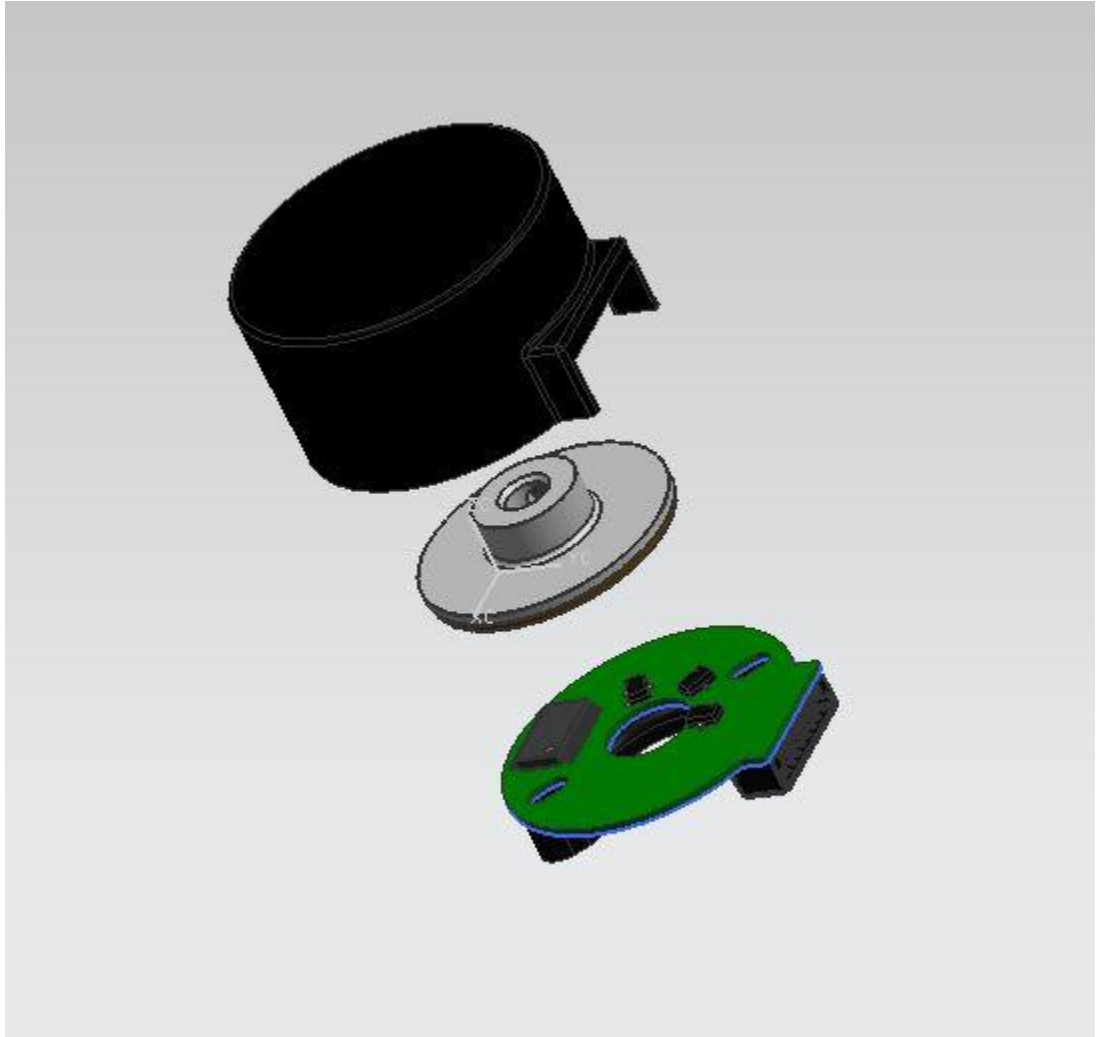

TIMKEN

Need help? Visit www.timkenencoders.com . You can also call our Technical Support Hotline phone numbers at 603-358-4737 or 603-355-4587.

Stronger. Commitment. Stronger. Value. Stronger. Worldwide. Stronger. Together. | Stronger. By Design.

M11 TO MOTOR INSTALLATION

- Make sure the encoder mounting surface is flat and clean.
- Place the supplied spacer on the motor.
- Set the M11 sensor board on the spacer and secure to the motor housing using two M2.5 X 0.45 X 8. The recommended height for the screw head is 1mm. Do not tighten the screws completely at this time.

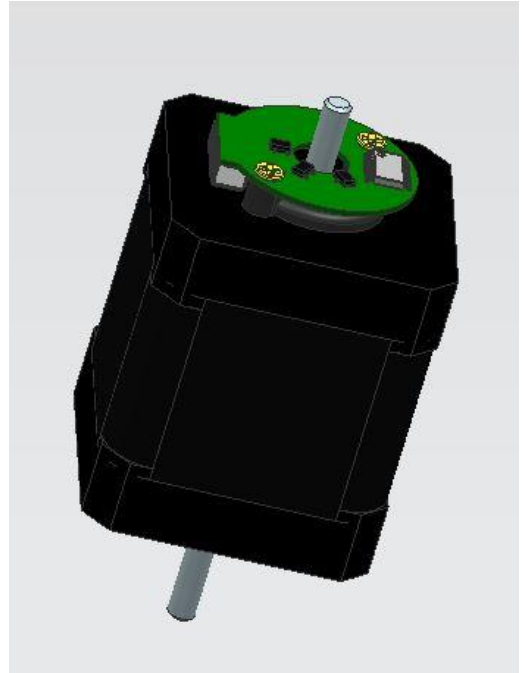
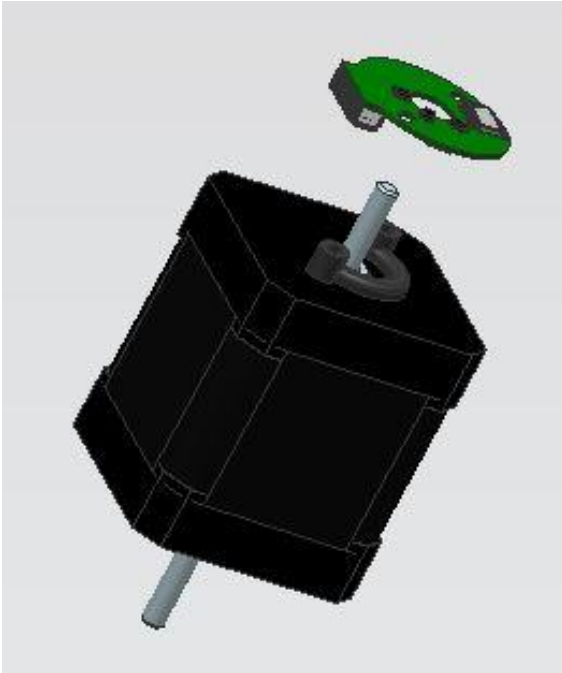

TIMKEN

- Slide the alignment tool down the motor shaft with the cone end towards the M11.
- Slightly rotate the M11 encoder as needed and center the encoder by lightly pushing the alignment tool into the center hole of the encoder.
- Tighten the screws to secure the encoder to the motor housing.
- Maintain a constant pressure on the alignment tool while tightening the screws.
- Remove the alignment tool.

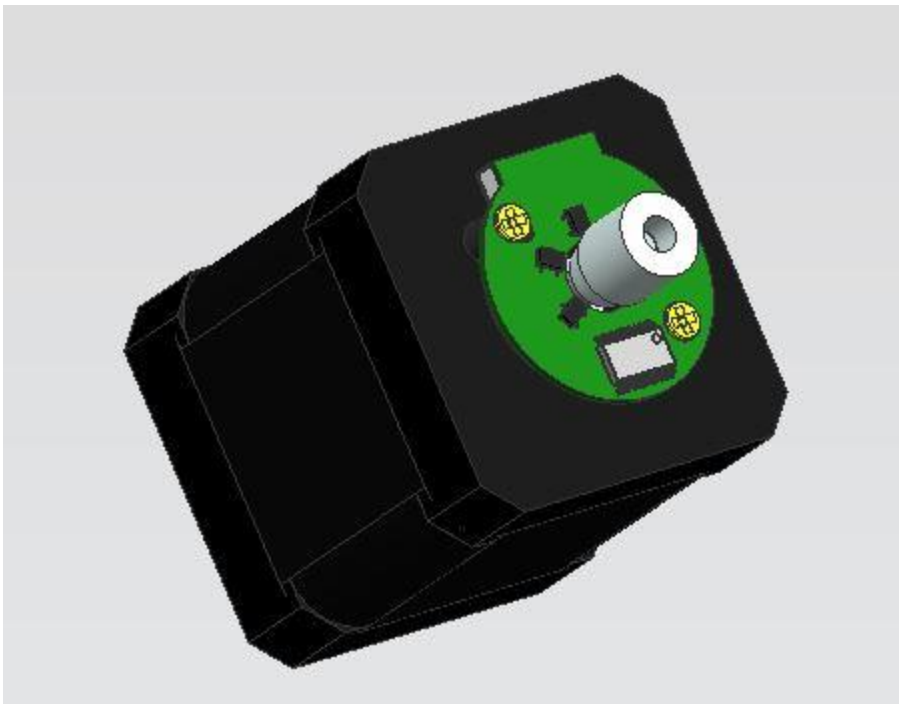

TIMKEN

- Slide the M11 magnetic target down the shaft.
- Position the air gap shim between the top of the MPS160 ASIC and the magnet material on the magnetic target.
- Using the supplied 1.5mm hex wrench, tighten the set screw on the magnetic target to a maximum torque of 3.9 kgf-cm.
- Remove the air gap shim.

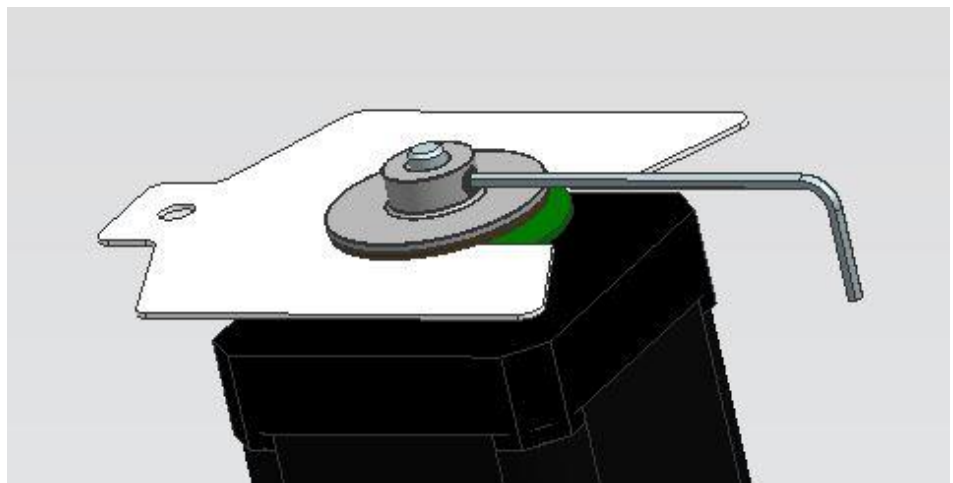
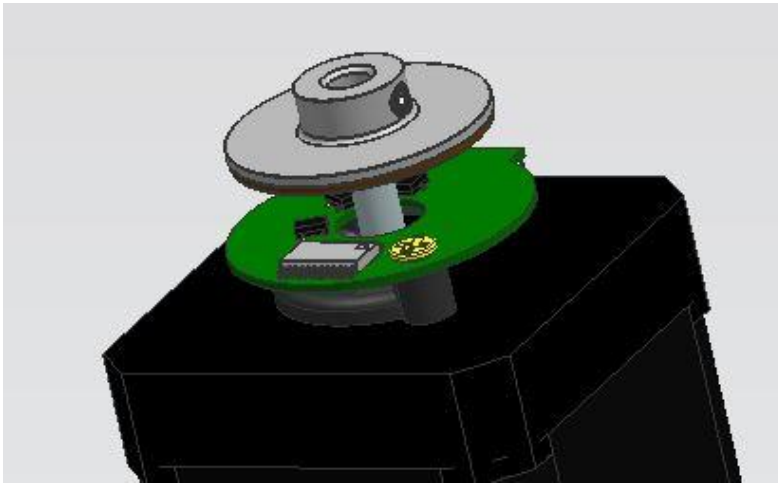

TIMKEN

- Place the plastic cover over the M11 and lightly press down towards the motor until it snaps on the M11 sensor board. Make sure to properly align the opening on the cover with the M11 connector.

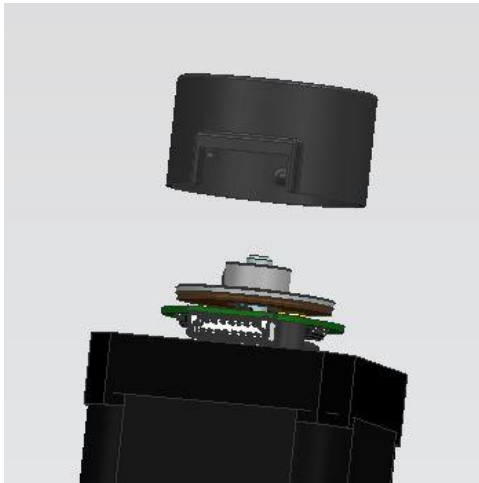

TIMKEN

M11 ENCODER AND ACCESSORIES

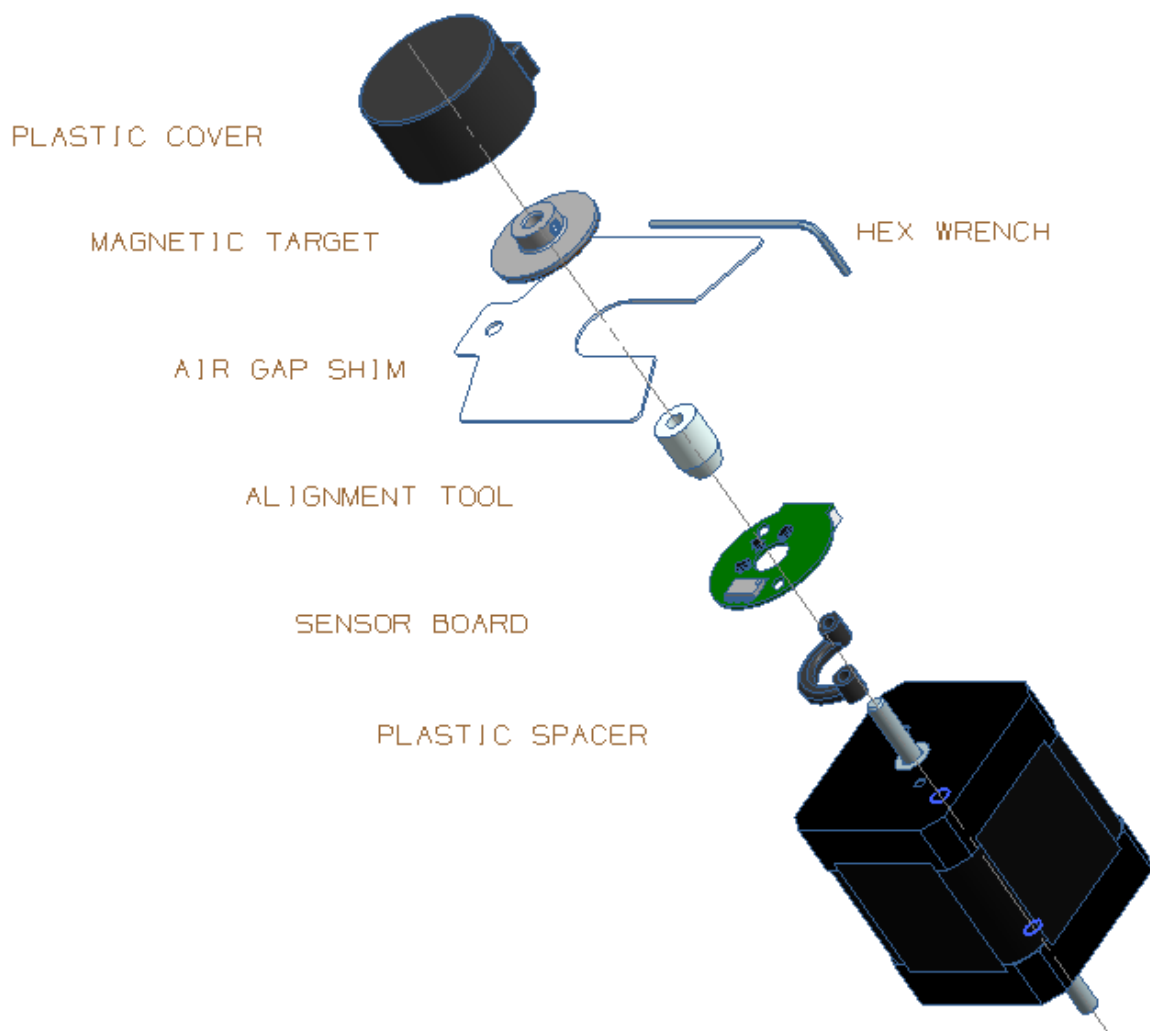

TIMKEN

M11 CABLE/PIN FUNCTIONS

Pin Number	Function	Color 15 Pin	Color 8 Pin
Pin 1	A+	YEL	Yellow
Pin 2	A-	YEL/WHT	White
Pin 3	B+	BLU	Blue
Pin 4	B-	BLU/WHT	Green
Pin 5	Index+	ORN	Orange
Pin 6	Index-	ORN/WHT	Brown
Pin 7	U+	GRN	NC
Pin 8	U-	GRN/WHT	NC
Pin 9	V+	BRN	NC
Pin 10	V-	BRN/WHT	NC
Pin 11	W+	WHT	NC
Pin 12	W-	WHT/GRY	NC
Pin 13	+5V	RED	Red
Pin 14	Ground	BLACK	Black



TIMKEN