

Multiplying Encoder ASIC

TIMKEN

Where You Turn

Specification Overview

Electrical

- DC supply voltage: 4.5V to 5.5V, 40 mA max.
- Low power mode (3 mA max.)
- Maximum output frequency: 800 kHz data rate
- Signal rise & fall time: $<1 \mu S$ (with 820 ohm pull up resistor)
- Multiple output drivers on chip:
 - Open drain - current sinking, 10 mA max.
 - Line driver outputs A, B, C
- Quadrature accuracy: $\pm 12.25^\circ$ (electrical)
- Position accuracy: $<0.09^\circ$ @ 12 bit (mechanical)

Environmental

- Shock load protected up to 100 G's
- Vibration resistant
- Variable air gap up to 2 mm in normal mode
- Unaffected by liquid or solid particulate in sensor-to-target gap
- Operating temperature: -40° to $125^\circ C^*$
- Electrostatic discharge protected to 2 kV
- Excellent EMI performance
- Rejection of common mode magnetic fields
- RoHS compliant
- TSSOP-24 package (8 mm X 6 mm X 1 mm)

*Contact Timken for higher temperatures

Resolution

- Programmable range of binary or decimal resolutions

Target Diameter	Resolution
1 inch (25 mm)	12 Bit
1.5 inch (38 mm)	13 Bit
2.7 inch (68 mm)	14 Bit

- Minimum linear resolution: 10 microns

Magnetic

- Pole size: 0.8 to 4.0 mm
- Minimum field strength: 50 Gauss
- Application-compatible magnetized polymer-bonded target magnets available



The Timken ASIC can be used in a variety of sensing applications.

The Timken Company's MPS 160, or advanced multiplying encoder ASIC, offers design engineers an alternative to delicate optical sensors and expensive resolvers. The fully integrated Timken design features on-chip Hall sensors and processing that provide optical encoder resolutions in a small durable, low-cost, off-axis magnetic encoder package.

Description

The Timken MPS 160 combines a direction-sensing Hall Effect encoder with integrated index pulses and a high accuracy resolution multiplying circuit. The result is a high resolution speed and position sensor system on a chip that is mounted off-axis to the shaft. The ASIC produces and processes Hall Effect signals to create high resolution quadrature output signals, providing zero speed and direction sensing.

When used with special magnetized targets, digital index signals are output by the chip and synchronized with the high resolution circuit signal.

As a multiplying encoder, the programmable output signal is up to 160 times the resolution of the pole pair count on the sensor's multi-pole magnetic target. This creates the high decimal or binary resolution normally associated with optical encoders.

The encoder ASIC offers flexibility for motor control circuitry in its ability to interface with external Hall sensors for commutation. When the external commutation Hall devices are routed through the encoder ASIC the absolute position of the motor over a motor phase is available through the encoder's SPI/ SSI interface.

The ASIC provides quadrature signals at speeds up to 200 kHz/channel (800 kHz data rate) and offers a low power mode operation.

TARGET/ASIC ORIENTATION AND CONNECTIONS

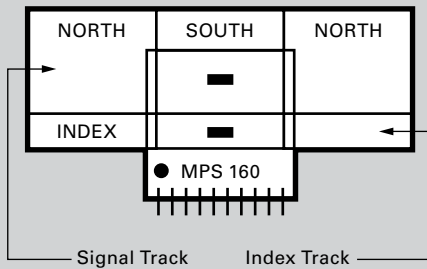

Connections:
Vcc, GND, Signal A, Signal B,
Signal C & Signal D, SPI



Magnetic targets can be manufactured in many sizes and configurations.

The robust Timken encoder ASIC operates reliably at higher temperatures, shock loads and vibration levels. It is also more tolerant of sensor-to-target variations (up to 5 mm air gap) and is not susceptible to particulate, liquid or solid contaminate between the sensor and magnetic target. This encoder is also packaged in a compact 8 mm x 6 mm chip.

Applications

- Encoders
- Brushless DC motors
- Rotary and linear positioning
- General-purpose motion control
- Automotive electric power assisted steering
- AC and DC motor internal speed control
- Motion control/sensing in industrial equipment
- Electric motor feedback in automotive accessories

Features And Benefits

- Fully integrated on-chip Hall sensor generates digital high resolution and programmable synchronized index pulse signals (C&D)
- Off-axis positions
- High shock and vibration resistance
- High temperature operating capability
- Operable with liquid or solid particulate in gap between sensor and target
- Large air gap
- Absolute position capability when used with external or commutation Hall devices
- SPI/SSI interface
- Low power mode
- Self diagnostics for air gap and internal errors
- Complete system on a chip
- Uses polymer bonded multi-pole magnets as rotary or linear targets
- AEC Q100 certified

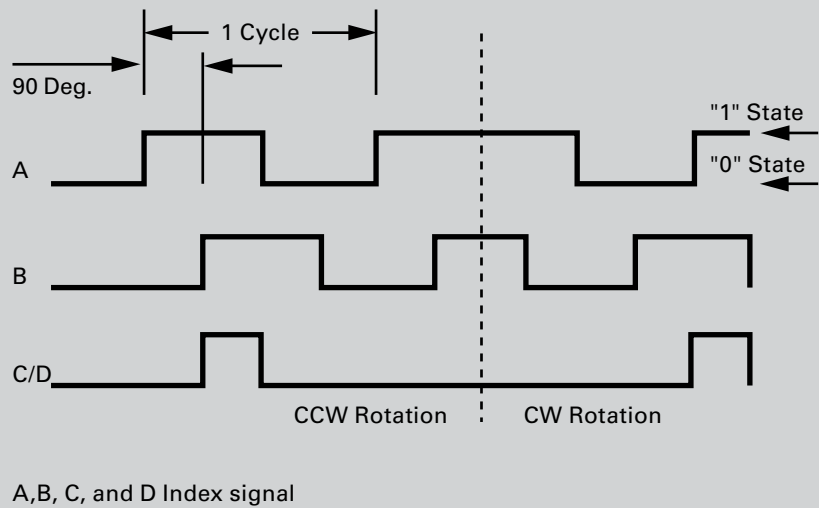

Wherever shafts, gears and wheels turn, Timken provides customers with advanced friction management solutions. These solutions include sensor technologies that help improve performance, extend equipment life and provide precise control in automotive, off-highway and industrial applications. With a large product offering including sensor-equipped bearings, condition monitoring and position sensors, Timken continues to meet motion control needs globally.

Please contact a Timken representative via email at motioncontrol@timken.com for more information.

TIMKEN

Where You Turn

Bearings • Steel •
Precision Components • Lubrication •
Seals • Remanufacture and Repair •
Industrial Services

www.timken.com/motioncontrol

Timken® is a registered trademark of
The Timken Company

© 2008 The Timken Company
Printed in U.S.A.
2.5M 10-08-29 Order No. 10112